

Instruction Manual

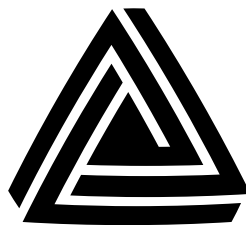

Anderson Instrument Co. Inc.
156 Auriesville Road
Fultonville, NY 12072
1-800-833-0081
Fax 518-922-8997

ANDERSON-NEGELE

Instrument Model Number _____

Instrument Serial Number _____

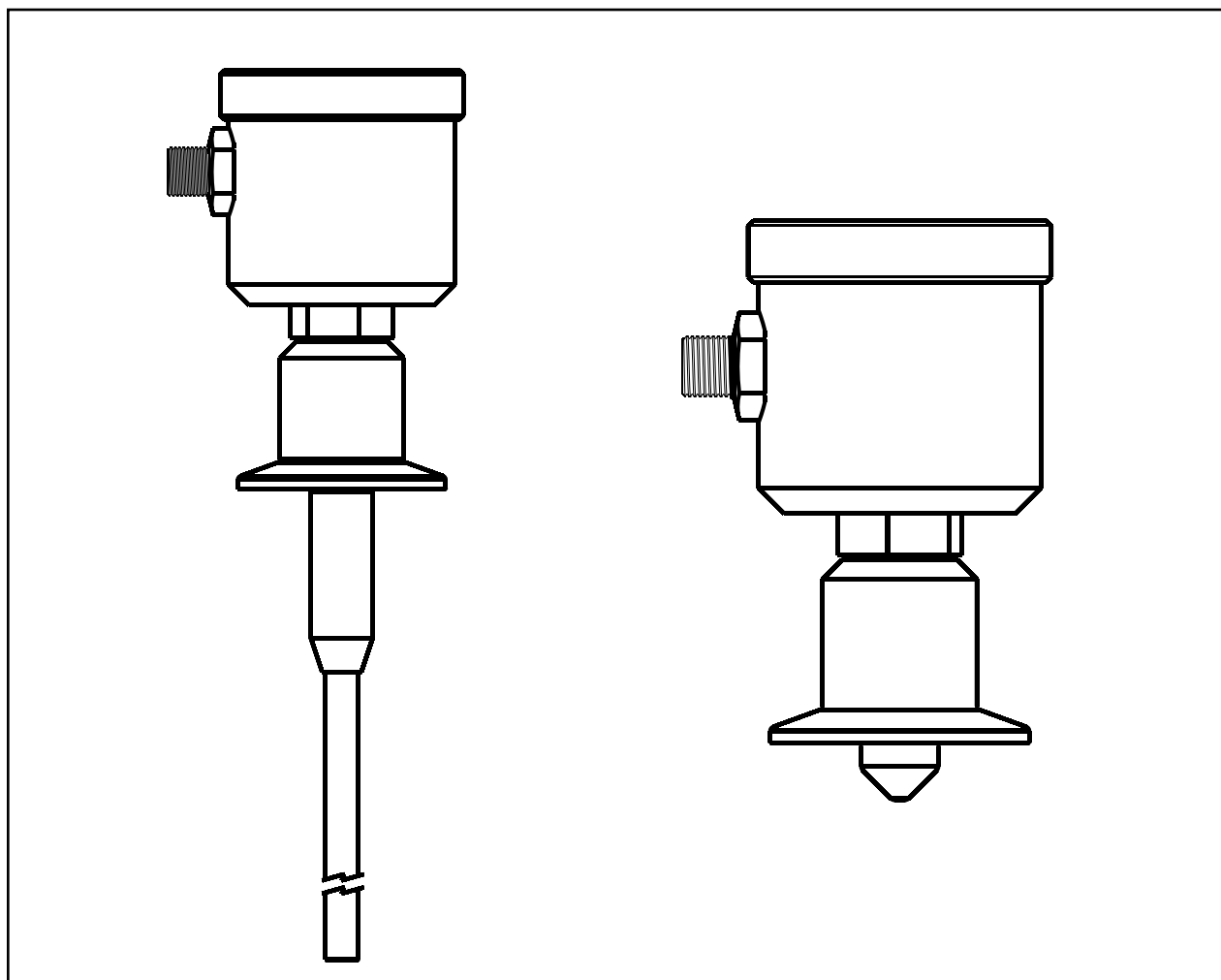

"LS" Capacitive Point Level Switch

Table of Contents

Section 1 - Application and Intended Use	5
1.1 - Application	5
1.2 - Intended Use	5
Section 2 - Specifications	5
Section 3 - Wiring	6
Section 5 - Maintenance	8
Section 6 - Dimensions	9
Section 7 - Part Number Matrix	10
Section 8 - Accessories	10
Warranty and Return Statement	11

Safety Warnings



Warning! This unit accepts DC voltage only, connection to AC voltage can cause failure of the sensor and/or risk of electrocution



Warning! Do not remove this sensor from the process while it is operating. Removal while the process is operating can contaminate the process and could cause human injury.



Warning! Do not subject this sensor to pressure that exceeds the specified upper range limit. Over-pressure may cause premature failure, incorrect output signal, or possible human injury.



Warning! Before removing for service or calibration, ensure that residual product has been flushed from the line and that internal pressure has returned to atmospheric pressure.

Section 1 - Application and Intended Use

1.1 - Application

The LS point level switch is a capacitance-based sensor designed to detect the presence or absence of liquid at the sensor tip. The on/off output can be used to provide an alarm, warning signal, or control signal to a pump or valve.

1.2 - Intended Use

The LS sensor is only to be used for the application that it has been designed, dimensioned and built for. The electrical connection must be to a direct current network (see the nameplate).

The intended purpose of the LS is the detection of process or cleaning fluids in the food processing, beverage, pharmaceutical and chemical industries. This sensor is not suitable for the measurement of hazardous, explosive, and combustible liquids of the PED group.

Any modifications to the sensor that might have an influence on the function and the safety features of the sensor are only allowed to be carried out by authorized persons of Anderson Instrument Company. Possible misuse including any use in contradiction to the above-mentioned application is an indication of misuse of the measuring instrument!

In such a case Anderson does not assume any responsibility for safety.

Section 2 - Specifications

Operation/Environmental Specifications

Ambient Temperature Limits:	14 - 140°F (-10 - 60°C)
Pressure Rating:	150 PSI (10 BAR) max
Process Temperature Limits:	32 - 212°F (0 - 100°C)
CIP Cleaning:	302°F (150°C) max 60 minutes
Function:	Full/empty signal determined by wiring
Response Time:	0.1s
Minimum Dielectric Threshold:	Selectable from 20-70
Enclosure Protection:	Designed and factory tested to NEMA 4x, IP69K; Suitable for use in wet environments at up to 100% relative humidity.

Electrical Specifications

Voltage Required:	24  (18 to 36 Vdc (≤ 20mA))
Power Consumption:	0.6 W Typ. (i.e. 25mA at 24 Vdc)
Signal Output:	PNP - Sourcing (active 50mA) Optional NPN - Sinking (max 50mA)
Signal Transmission Power:	≤ 1mw
Connection:	One 3 pin M12 Micro-mini electrical connector (QDR)

Mechanical Specifications

Wetted Materials:	316L Stainless Steel, PEEK
Wetted Finish:	Better than $R_a=32$
Housing Material:	300 series Stainless Steel housing, lid and threaded connection (non contact surfaces)
Agency Approval:	CE compliant; 3-A compliant, Third party verified ETL Listed Conforms to UL Std 61010-1 3rd Ed(with Display Window option "0" only) Certified to CSA Std C22.2 61010-1 3rd Ed(with Display Window option "0" only)

Visual Indication

Status LED:	Red - Probe Immersed Green - Probe Dry
-------------	---

Warranty:	2 years
-----------	---------

Section 3 - Wiring



Warning!

This unit accepts DC voltage only, connection to AC voltage can cause failure of the sensor and/or risk of electrocution

Figure 1.1 - Field Wireable Connector Assembly

1. Insert cable through Pressing Screw, Compression Ring, Seal Grommet, and Sleeve as shown below.
2. Strip back 1-1/4" of outer sheathing, cut off any excess wires, shield and ground. Strip off 1/4" insulation from remaining four wires. It is not necessary or recommended to tin the wires.
3. Orient Connector end so that center pin connecting screw is horizontal facing right (see detail).
4. Refer to pin detail.
 4A - Wiring for full (immersed) indication: Wire PWR+ to top right terminal (Pin 1) and PWR- wire to bottom left (Pin 3). Wire output to bottom right (Pin 4).
 4B - Wiring for empty (not immersed) indication: Wire PWR- to top right terminal (Pin 1) and PWR+ to bottom left (Pin 3). Wire output to bottom right (Pin 4).

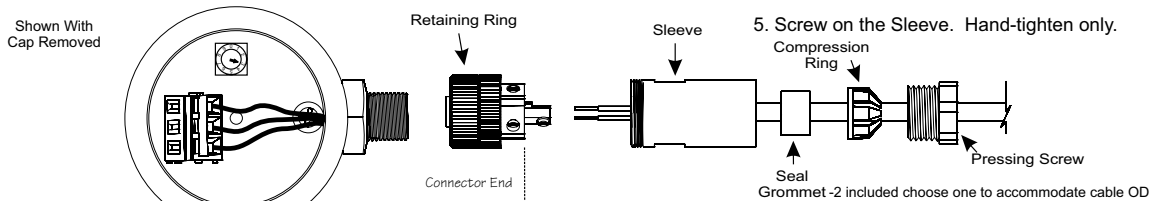

CABLE REQUIREMENTS

3 conductor, stranded, 18-24 AWG, shielded with ground.
 4-8mm (0.16-0.31") Cable Sheath OD.

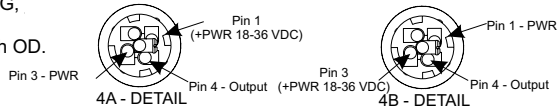

5. Screw on the Sleeve. Hand-tighten only.

6. Press the Seal Grommet into the Sleeve and hand-tighten the Pressing Screw against the compression ring.

7. Use a wrench to tighten the Pressing Screw another 3/4 turn. Do not over-tighten!

To install connector, simply line up key, press into receptacle, and hand-tighten the retaining ring.

*Receptacle pins should be coated with USDA approved dielectric grease to Minimize possibility of corrosion.

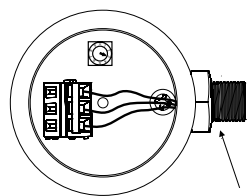

*Dielectric Grease
 P/N: 5662400000

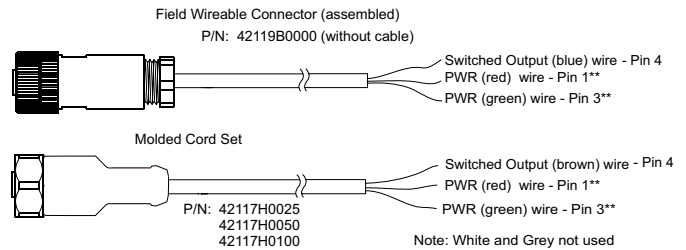

** Polarity determined by desired switch action. See switch action below.

Section 4 - Installation and Sensitivity Adjustment



Warning! Do not subject this sensor to pressure that exceeds the specified upper range limit. Over-pressure may cause premature failure, incorrect output signal, or possible human injury.

Caution: For proper mounting of this sensor, verify that the fitting connection type, size, gasket or seal, and holding ring or clamp match the process connection it is being mounted to. Improper mounting can cause process leakage, reduced pressure ratings, and/or contamination issues.

Caution: Do not open the sensor enclosure in wet or spray-down environments. Moisture ingress can cause premature electronics failure.

Caution: Handle with care during installation to avoid damage to the sensor. Physical damage, especially to the sensing surface or probe can cause incorrect output signal or premature failure.

Caution: Do not expose the sensor to process or ambient temperatures that exceed the rated specifications. Physical damage, incorrect output signal, or premature failure may result.

Select Switch Action:

- Switch action is determined by power supply polarity. If field wireable connector is used see instruction 4 in section 1 for wiring instructions. If assembly cable is purchased connect Red conductor to PWR+ (18-36V) and Green conductor to PWR- for full (immersed) indication. Reverse these for empty (not immersed) indication.

Rotary Switch Output Test & Threshold Adjustment:

- For installation testing sensor may be set for continuous output:
 Position 0 - output off
 Position 1 - output on
- Positions 2-9 act as a sensitivity adjustment, position selects a minimum dielectric recognized. Reducing dielectric threshold can help eliminate false readings.

- | | |
|------------------------------|------------------------------|
| Position 2 - ≥ Dielectric 20 | Position 6 - ≥ Dielectric 40 |
| Position 3 - ≥ Dielectric 25 | Position 7 - ≥ Dielectric 50 |
| Position 4 - ≥ Dielectric 30 | Position 8 - ≥ Dielectric 60 |
| Position 5 - ≥ Dielectric 35 | Position 9 - ≥ Dielectric 70 |

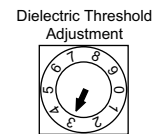

Output Circuit:

Standard unit is PNP output see detail for connection
 Optional unit is NPN output see detail for connection

Misc:

- Media must have water content >25% or a dielectric constant >20
- Coatings are generally ignored. Coatings of highly conductive media ≥ 30ms/cm may cause errors.
- Foam is generally ignored

HIGH ACTIVE
FULL INDICATION

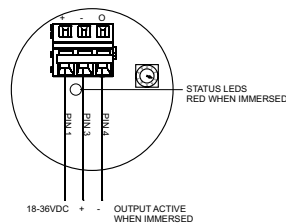

LOW ACTIVE
EMPTY INDICATION

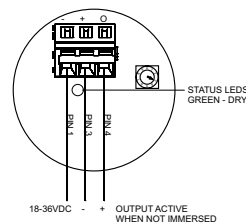

PNP - Sourcing

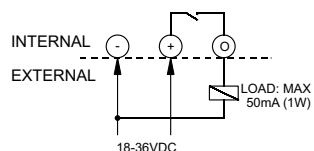

NPN - Sinking

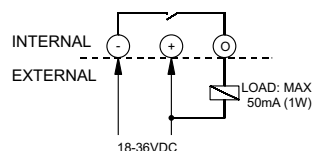

Section 5 - Maintenance



Warning! Do not remove this sensor from the process while it is operating. Removal while the process is operating can contaminate the process and could cause human injury.



Warning! Before removing for service or calibration, ensure that residual product has been flushed from the line and that internal pressure has returned to atmospheric pressure.

Caution: Attempting to disconnect or change wiring to this sensor during process operation can cause loss of signal to the control system!

Caution: Improper changes to sensitivity setting following installation and commissioning can result in false output signal.

Caution: Improper replacement of components during service can result in process leakage, reduced pressure rating, system cleanability issues, or incorrect output signal.

The LS is designed to provide years of trouble-free service, but should be checked annually by removing from the process for a visual inspection and operational verification. The PEEK probe tip should be free from cracks or deep scratches.

To check for proper operation, first determine the status of the switch with the probe in air (no product touching the tip). Depending on wiring, the status light may be on or off. Now immerse the probe tip in the target fluid and watch for a change in the status light. It should go from on to off, or from off to on. If there is no damage and the unit is functioning as expected, the unit can be re-installed in the process. If it is damaged or not functioning properly, we suggest replacing it and return the unit to the factory for repair or replacement.

Caution: Verify that the sensor is operating properly after service, and prior to start-up of control system. When power is first applied, immerse sensor tip in target liquid and observe status change on indicator light.

External cleaning instructions: The external surfaces of this sensor can be cleaned along with the equipment or piping system that it is installed on, using cleaning and disinfecting solutions designed for use on hygienic equipment.

Section 6 - Dimensions

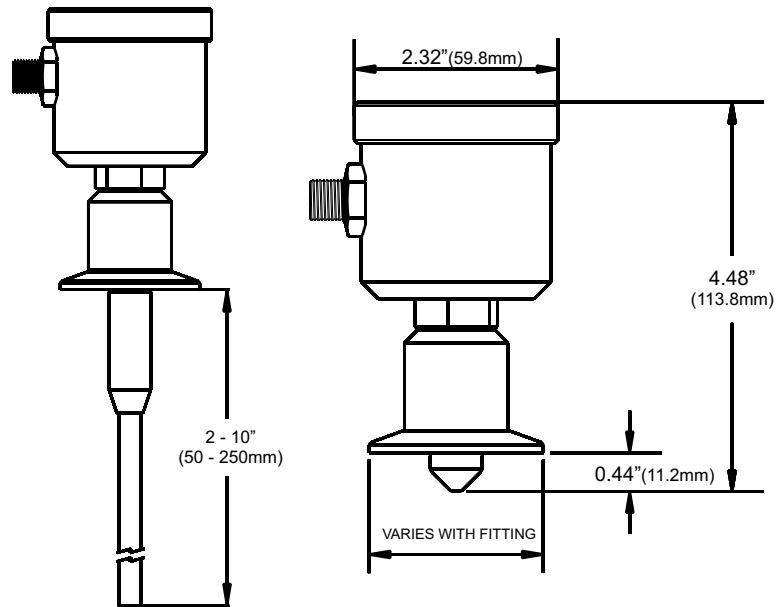

Weight: 2" Tri-Clamp® 1.85 lbs. (.84kg)
1.5" Tri-Clamp® 1.65 lbs. (.75kg)

Section 7 - Part Number Matrix

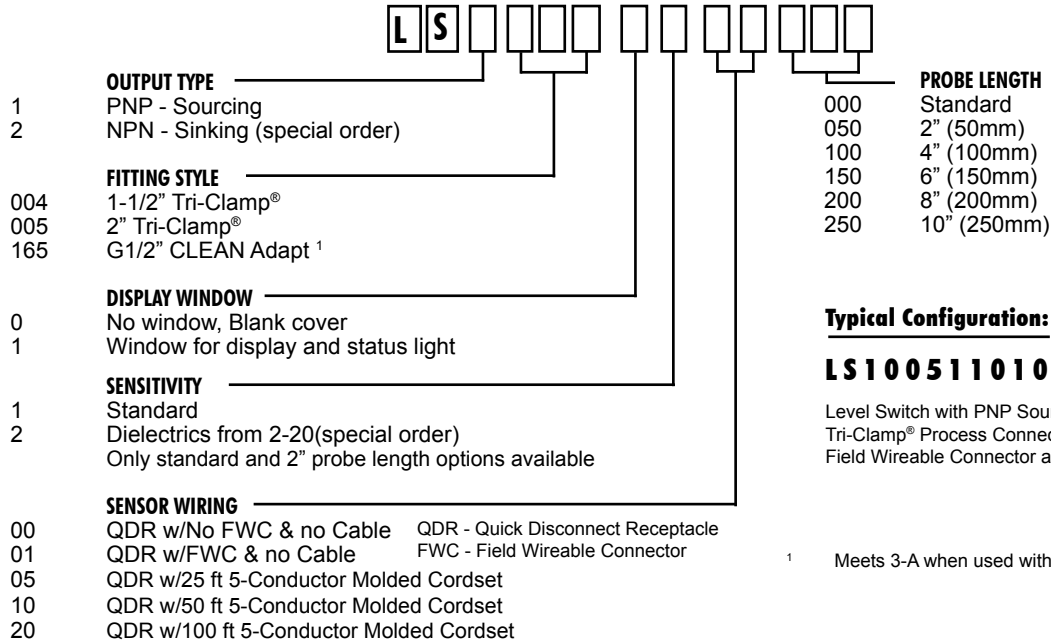

Typical Configuration:

LS10051101000

Level Switch with PNP Sourcing Output, 2" Tri-Clamp® Process Connection, Window Display, Field Wireable Connector and Standard Probe.

¹ Meets 3-A when used with a 3-A compliant adapter

Section 8 - Accessories

- Molded Cordsets
- P/N 42117H0025: 25 foot
- P/N 42117H0050: 50 foot
- P/N 42117H0100: 100 foot

Warranty and Return Statement

These products are sold by The Anderson Instrument Company (Anderson) under the warranties set forth in the following paragraphs. Such warranties are extended only with respect to a purchase of these products, as new merchandise, directly from Anderson or from an Anderson distributor, representative or reseller, and are extended only to the first buyer thereof who purchases them other than for the purpose of resale.

Warranty

These products are warranted to be free from functional defects in materials and workmanship at the time the products leave the Anderson factory and to conform at that time to the specifications set forth in the relevant Anderson instruction manual or manuals, sheet or sheets, for such products for a period of two years.

THERE ARE NO EXPRESSED OR IMPLIED WARRANTIES WHICH EXTEND BEYOND THE WARRANTIES HEREIN AND ABOVE SET FORTH. ANDERSON MAKES NO WARRANTY OF MERCHANTABILITY OR FITNESS FOR A PARTICULAR PURPOSE WITH RESPECT TO THE PRODUCTS.

Limitations

Anderson shall not be liable for any incidental damages, consequential damages, special damages, or any other damages, costs or expenses excepting only the cost or expense of repair or replacement as described above.

Products must be installed and maintained in accordance with Anderson instructions. Users are responsible for the suitability of the products to their application. There is no warranty against damage resulting from corrosion, misapplication, improper specifications or other operating condition beyond our control. Claims against carriers for damage in transit must be filed by the buyer.

This warranty is void if the purchaser uses non-factory approved replacement parts and supplies or if the purchaser attempts to repair the product themselves or through a third party without Anderson authorization.

Returns

Anderson's sole and exclusive obligation and buyer's sole and exclusive remedy under the above warranty is limited to repairing or replacing (at Anderson's option), free of charge, the products which are reported in writing to Anderson at its main office indicated below.

Anderson is to be advised of return requests during normal business hours and such returns are to include a statement of the observed deficiency. The buyer shall pre-pay shipping charges for products returned and Anderson or its representative shall pay for the return of the products to the buyer.

Approved returns should be sent to: ANDERSON INSTRUMENT COMPANY INC.
156 AURIESVILLE ROAD
FULTONVILLE, NY 12072 USA

ATT: REPAIR DEPARTMENT

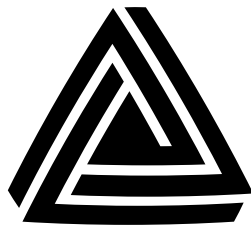

ANDERSON-NEGELE

ANDERSON INSTRUMENT CO., INC • 156 AURIESVILLE RD. • FULTONVILLE, NY 12072 • USA • 800-833-0081 • FAX 518-922-8997
ANDERSON INSTRUMENT CO. LP • 400 BRITANNIA RD. EAST, UNIT 1 • MISSISSAUGA, ONTARIO L4Z 1X9 • CANADA • 905-603-4358 • FAX 905-568-1652
NEGELE MESSTECHNIK GmbH (A Division of Anderson) • RAIFFEISENWEG 7 • D-87743 EGG A. D. GÜNZ • GERMANY • +49 (0) 8333/9204-0 • FAX +49 (0) 8333/9204-49

www.anderson-negele.com